

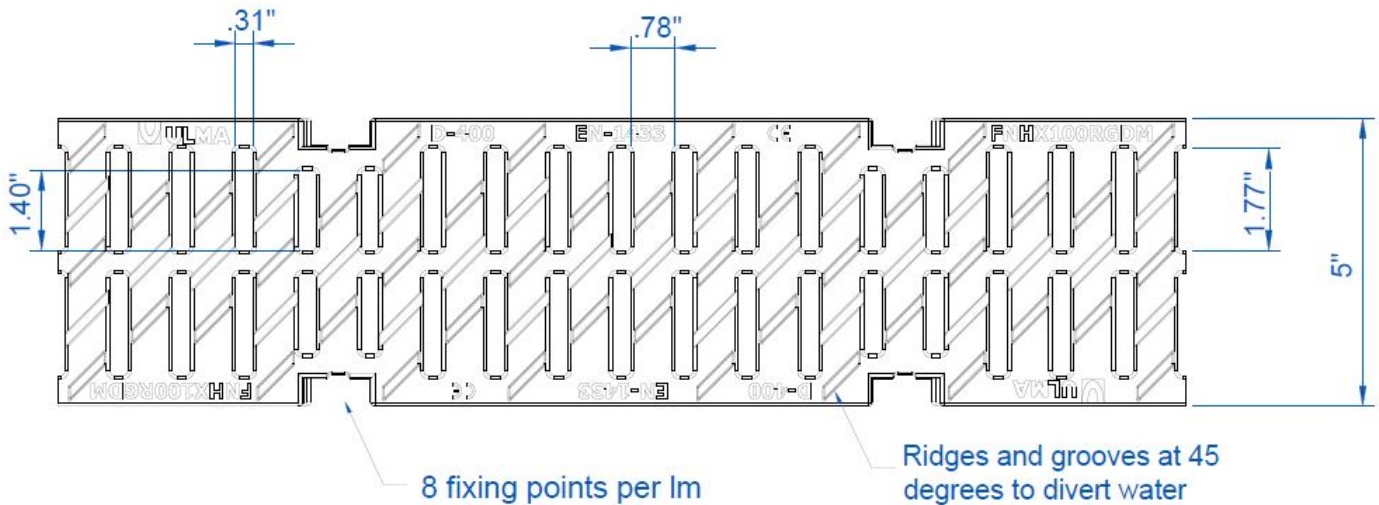

|  |  |
|--|--|
| <p><b>Number</b></p> <p><b>FNHX100RGDM</b></p> | <p><b>Series</b></p> <p><b>ULG100</b></p> <p>D Class Ductile Iron ADA Grate</p> <p>MultiV100</p> |
|--|--|

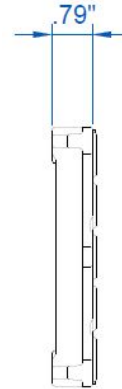

**D Class**



|  |   |
|--|---|
| <p><b>Manufacturer</b></p>  | <p><b>Specification</b></p> <p>ULMA MULTIV100 SERIES ADA GRATE. LOAD CLASS D400 EN 1433 STANDARD. ADA AND HEELPROOF. CASTED ESPHERIODAL GRAPHITE DUCTILE IRON, EN 1563 STANDARD. BOLTLESS RAPIDLOCK LOCKING SYSTEM SUPPLIED BY TRENCH DRAIN SUPPLY.</p> |
|--|---|

DISCLAIMER - The customer and the customer's architects, engineers, consultants, and other professionals are completely responsible for the selection installation and maintenance of any product purchased from Trench Drain Supply and/or its manufacturers. TRENCH DRAIN SUPPLY MAKES NO WARRANTY, EXPRESS OR IMPLIED, AS TO THE SUITABILITY, DESIGN, MERCHANTABILITY, OR FITNESS OF THE PRODUCT FOR CUSTOMERS APPLICATION. The drawing and information provided remain the property and copyright of the manufacturer listed. The manufacturer reserves the right to modify specification without notice.